

CUSTOMER: P/N: 0310.120ALLT REV. APPROVED BY:

REVISIONS		
REV.	DESCRIPTION	DATE
△		
△		
△		
△		
△		

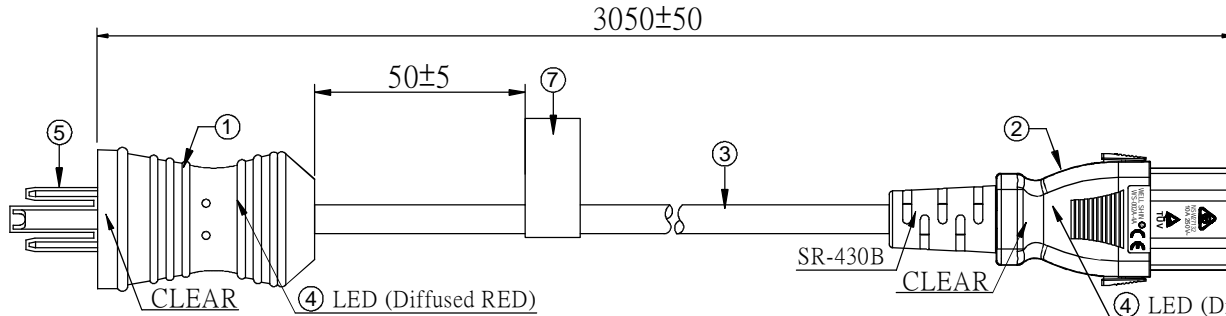

NOTES:

- LED DIFFUSED RED LIGHT
*(PART NUMBER: LER1L034MA201MA)
- CARBON ELECTRICITY GROUP 51K 1/4W 5%
*(PART NUMBER: CFA1/4W051K5MA)
- RoHS

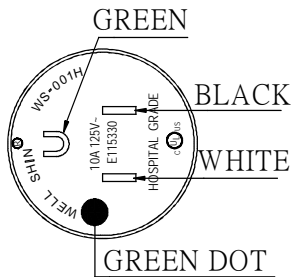

NEMA 5-15P HOSPITAL GRADE CLEAR WITH LED

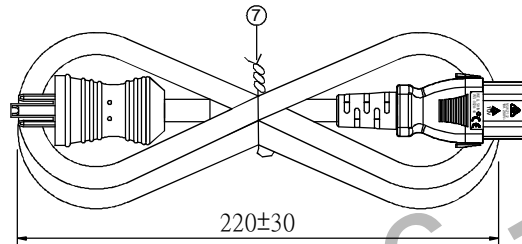

IEC-60320-C13 AUTO-LOCK CLEAR WITH LED

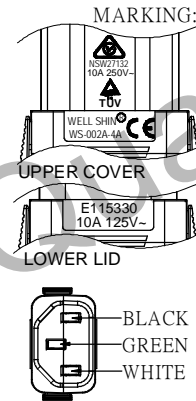

⑦	Cable tie	WHITE	1
⑥	Hosp.Grade label	---	1
⑤	PLASTIC CAP	WHITE	1
④	LED (Diffused Red) # 1L034XV22D0MA201 + CARBON FILM RESISTORS 51K 1/4W 5%	RED	2
③	SJTW 18AWG*3C 105°C APPROVAL : UL,CSA	Pantone Cool Grey 9C (GY-H)	1
②	WS-002A-4A 10 (A) 125 (V) APPROVAL : UL,C-UL,TUV,SAA,CE	CLEAR	1
①	WS-001H 10 (A) 125 (V) APPROVAL : UL,C-UL		1
ITEM	DESCRIPTION	COLOR	Q'TY

⑥Hosp.Grade label

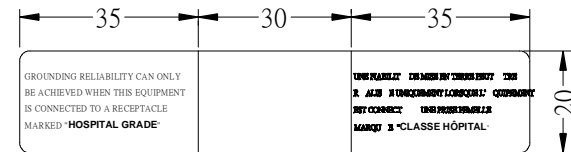

SIGNATURE		QUAIL ELECTRONICS, INC. http://www.quail.com	
SAFETY ENGINEER:		PRODUCT NO: 001H+002A-4A	DATE: 2016/06/14
MANAGER BY:		UNIT: mm	SHEET: 1 OF 1
CHECKED BY:		REV.	
DRAWN BY:		DWG NO: 0096-5721	